

Ultrasonic Acoustic Stack Mounting Guidelines

Correct acoustic stack mounting is vital to process consistency and equipment life.

- 1) The ultrasonic stack should be supported in two locations. The two supports should be machined together or connected by a common plate which is rigid and prevents deflection, torsion and bending of the stack. A minimum of 0.5" (13mm) thick aluminum or steel plate should be used.
- 2) The bores of the two supports must be concentric within 0.005" (.1mm) and must allow for a clearance of 0.003"-0.010" oversize with respect to the booster/ horn and transducer clamping ring diameters. This insures that there is no bending or excessive compression force applied to the booster/horn rings and transducer housing.
- 3) The booster/horn support should be designed with upper and lower ridges to prevent the ultrasonic stack from falling out of the support and to provide a thrust surface for axial forces. The support ridge should be 0.100"-0.150" (2.5mm) wide and should allow at least 0.005" (0.1mm) axial clearance to prevent the booster/horn clamp ring from binding in the support and to make installing and removing the ultrasonic stack easier.
- 4) The support design should incorporate slots or other mounting provisions which allow for variation in stack component lengths. Boosters and horns can vary up to 0.5" (13mm) due to material properties. This may require an adjustment to the height of the stack above the product.
- 5) Supports which use split clamps are preferred for easy setup and adjustment. A minimum of 0.025" (1mm) gap should be maintained between the upper and lower sections of a split clamp. Inadequate or excessive clamping force can cause premature equipment failure and/or noisy operation. The bolt torque spec is 15 ft-lb (20 N-m) for a 1/4-20 screw (6mm).
- 6) Supports and other machinery must be designed so that there is no contact with the horn or booster except in designated clamping areas as per the guidelines in this document. Any other horn, booster or transducer contact could result in premature equipment failure and/or noisy operation.
- 7) Machinery should be designed to allow for free ultrasonic cable movement without binding. The minimum cable bending radius is 2.5" (65mm).
- 8) Machinery should be designed so that the cutting or welding forces are axial to the centerline of the ultrasonic stack and parallel to the face of the sonitrode / horn. Offset or side loading can cause equipment failure and/or noisy operation. Typically, 1 to 3 CFM of air flow is required to achieve adequate cooling but an exact value is application dependent.
- 9) Proper acoustic stack assembly is critical. The ultrasonic booster end which must be attached to the ultrasonic horn is marked on the booster. Refer to the Dukane white paper for more detailed information on assembling and maintaining the ultrasonic stack.
- 10) Clean dry air for cooling must be provided to the ultrasonic stack assembly including the transducer. Cooling air must be filtered (5u or better) to 5 microns. No electrically conductive media or condensing water vapor is permitted inside the transducer housing. Additional cooling should be provided to the booster and horn to prevent any part of the ultrasonic stack assembly from exceeding 110F° (43°C). Exhaust air from the transducer may be utilized to cool other portions of the ultrasonic stack. (See bullet "I" on inside).
- 11) Dukane "S" series transducers are rated for IP65. Additional low pressure washdown is permitted but submersion and high pressure washdown may compromise the transducer seals. Consult factory for higher ratings on a case by case basis. Dukane components are made from anodized aluminum, stainless steel and titanium with Viton and Neoprene seals. Material compatibility with cleaning solutions should be verified before putting equipment into service.
- 12) To conform with UL 61010-1 and CAN/CSA-22.2, the empty space between the receptacle and plug inside all 3 pin MIL-SPEC connectors shown in image (see call out M) must be filled with Dow Corning #4 electrical insulating compound. This does not apply to other connector types.

Dukane Open Probe Mount EX-8331-00

- A. Common mounting plate to ensure concentricity between converter, booster and horn flat +/- 0.0005" (0.013mm).
- B. Slotted mounting holes on common back plate to accommodate changes in horn and booster lengths.
- C. Mount designed with undercuts to take up load from process on booster clamp ring surfaces.
- D. No deflection permitted. Mount should prevent stress and deflection on booster converter interface due to misalignment.
- E. Mount must maintain correct bore tolerances for booster clamp ring and probe. + 0.005" – 0.000" (0.127mm -0 .000mm). Bores to be concentric. +/- 0.005" (0.127mm).
- F. Inadequate or excessive clamping force on the these components can cause premature equipment and process failures. Bolt clamp torque specification is 15 lb.ft (20 Nm) 4 places.
- G. Air cooling input, sufficient to prevent acoustic stack (horn/sonotrode, booster, converter) from exceeding 110°F (43°C). (Application/process dependent)
- H. Cable placement to eliminate strain or sharp bends.
- I. Exhaust air may be plumbed to provide additional cooling to converter output end and horn (See Figure A, Page 4.)
- J. Nothing to come in contact with transducer output, booster body or sonotrode/horn. Do not attach to, or modify these components.
- K. Ensure proper orientation of booster, output end to sonotrode/horn.
- L. Load to be centered and parallel to face of sonitrode/horn. Minimize side load of acoustic stack.
- M. Reference guideline 12 on the previous page for electrical insulation requirements.



Proper acoustic stack assembly is critical

Please see:

*Ultrasonic Probes/Stacks-Understanding and Caring
for the Heart of your Ultrasonic System*

http://www.dukane.com/us/SE_Stackarticle.htm

Dukane Open Probe Mount EX-8331-00



Ultrasonic Acoustic Stack Mounting Drawings

EX-8331-00 standard probe mounts shown with
Dukane 41S30 sealed 20 kHz stainless steel
IP65 rated converter and titanium booster

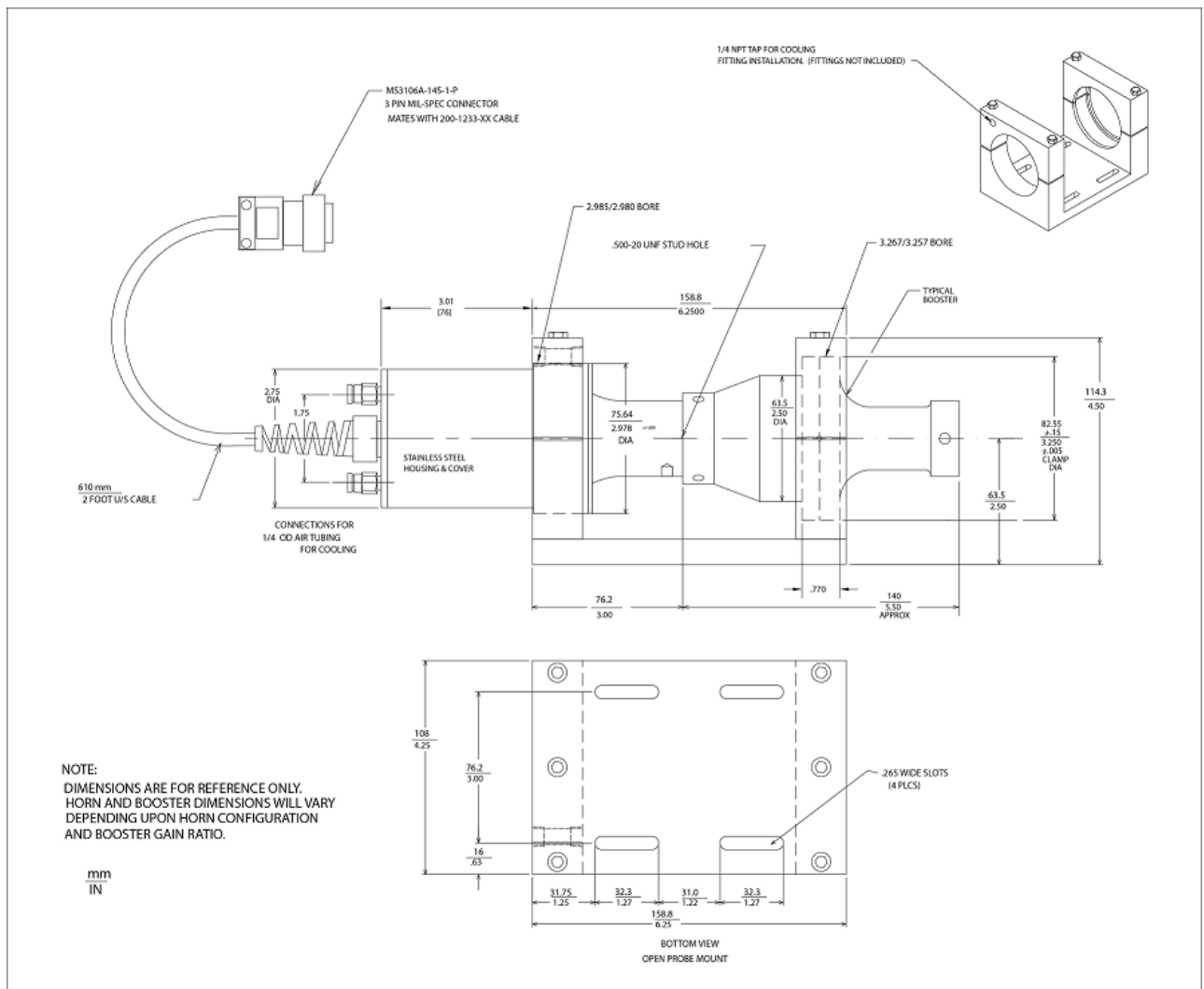
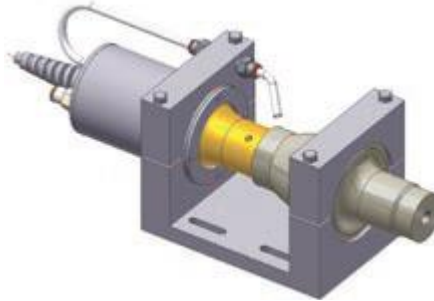

Troubleshooting Tips

Problem - excess noise or system overload.

1. Ensure proper cooling is in place.
2. Inspect complete acoustic stack for over temperature. Components that have experienced excessive heat may be permanently damaged, consult factory before putting units back in production.
3. Remove acoustic stack from mount. Inspect for missing components; inspect for nicks, cracks, scrapes or evidence of metal to metal contact.
4. Inspect mount to ensure proper clamp torque and tolerances.
5. Disassemble and re-assemble acoustic stack following proper procedures. See, Ultrasonic Probes/Stacks - Understanding and caring for the heart of your ultrasonic system white paper.
<http://www.dukane.com/us/Documents/DesignGuides/Ultrasonic Probes.pdf>
6. If problem still exists, contact the manufacturer.

Visit http://www.dukane.com/us/DL_DrawingsLayout.asp for downloadable drawings PDF, DWG, DXF & STP.

20 kHz Standard Mount EX-8331-00
20 kHz Narrow Mount EX-8468-00
30/40 kHz Standard Mount EX-8471-00
15 kHz Standard Mount EX-8470-00

Available in anodized aluminum or stainless steel

Note: All specifications are subject to change without notice. Please consult Dukane IAS, LLC for any updated information.

Dukane IAS, LLC
Intelligent Assembly Solutions

2900 Dukane Drive
St. Charles, IL 60174 USA
Tel: (630) 797-4900
Fax: (630) 797-4949
<http://www.dukane.com/us>

Disclaimer: Dukane IAS, LLC assumes no responsibility for any errors which may appear in this document, reserves the right to change devices or specifications detailed herein at any time without notice, and does not make any commitment to update the information contained herein.

DOCUMENT INFO:

DATE: 06/06/2016
ECN:
DRAWN: DSS
CHECKED:
APPROVED:
ENGINEER:

REVISION INFO:

ISS	DESCRIPTION	APPD	DATE
01	Added document/revision page. ECN 9825	DSS	06/06/2016
02	Updated guideline 10 and added guideline 12. ECN 10131	RA	06/20/2017
03	On Page 1, Step 4, 0.50" was 5.0". ECN 10136	DSS	08/30/2017